



XV1700PCR XV1700PCRC

SUPPLEMENTARY SERVICE MANUAL

FOREWORD

This Supplementary Service Manual has been prepared to introduce new service and data for the XV1700PCR/XV1700PCRC. For complete service information procedures it is necessary to use this Supplementary Service Manual together with the following manual.

XV1700P/XV1700PC SERVICE MANUAL: LIT-11616-15-37 (5PX-28197-10)

**XV1700PCR/XV1700PCRC
SUPPLEMENTARY
SERVICE MANUAL
©2002 by Yamaha Motor Corporation, U.S.A.
First Edition, July 2002
All rights reserved.
Any reproduction or unauthorized use
without the written permission of
Yamaha Motor Corporation, U.S.A.
is expressly prohibited.
Printed in U.S.A.
LIT-11616-16-36**

NOTICE

This manual was produced by the Yamaha Motor Company, Ltd. primarily for use by Yamaha dealers and their qualified mechanics. It is not possible to include all the knowledge of a mechanic in one manual. Therefore, anyone who uses this book to perform maintenance and repairs on Yamaha vehicles should have a basic understanding of mechanics and the techniques to repair these types of vehicles. Repair and maintenance work attempted by anyone without this knowledge is likely to render the vehicle unsafe and unfit for use.

This model has been designed and manufactured to perform within certain specifications in regard to performance and emissions. Proper service with the correct tools is necessary to ensure that the vehicle will operate as designed. If there is any question about a service procedure, it is imperative that you contact a Yamaha dealer for any service information changes that apply to this model. This policy is intended to provide the customer with the most satisfaction from his vehicle and to conform to federal environmental quality objectives.

Yamaha Motor Company, Ltd. is continually striving to improve all of its models. Modifications and significant changes in specifications or procedures will be forwarded to all authorized Yamaha dealers and will appear in future editions of this manual where applicable.

NOTE:

Designs and specifications are subject to change without notice.

IMPORTANT MANUAL INFORMATION

Particularly important information is distinguished in this manual by the following.



The Safety Alert Symbol means ATTENTION! BECOME ALERT! YOUR SAFETY IS INVOLVED!

⚠ WARNING

Failure to follow WARNING instructions could result in severe injury or death to the motorcycle operator, a bystander or a person checking or repairing the motorcycle.

CAUTION:

A CAUTION indicates special precautions that must be taken to avoid damage to the motorcycle.

NOTE:

A NOTE provides key information to make procedures easier or clearer.

HOW TO USE THIS MANUAL

This manual is intended as a handy, easy-to-read reference book for the mechanic. Comprehensive explanations of all installation, removal, disassembly, assembly, repair and check procedures are laid out with the individual steps in sequential order.

- ① The manual is divided into chapters. An abbreviation and symbol in the upper right corner of each page indicate the current chapter.
Refer to "SYMBOLS".
- ② Each chapter is divided into sections. The current section title is shown at the top of each page, except in Chapter 3 ("PERIODIC CHECKS AND ADJUSTMENTS"), where the sub-section title(s) appears.
- ③ Sub-section titles appear in smaller print than the section title.
- ④ To help identify parts and clarify procedure steps, there are exploded diagrams at the start of each removal and disassembly section.
- ⑤ Numbers are given in the order of the jobs in the exploded diagram. A circled number indicates a disassembly step.
- ⑥ Symbols indicate parts to be lubricated or replaced.
Refer to "SYMBOLS".
- ⑦ A job instruction chart accompanies the exploded diagram, providing the order of jobs, names of parts, notes in jobs, etc.
- ⑧ Jobs requiring more information (such as special tools and technical data) are described sequentially.

②

CLUTCH

①

ENG

④

⑤

⑥

⑦

Order	Job/Part	O'ty	Remarks
Removing the clutch cover			
	Left side cover		Remove the parts in the order listed. Refer to "SEAT AND SIDE COVERS" in chapter 3.
	Sub fuel tank		Refer to "SUB FUEL TANK" in chapter 3.
	Engine left side cover		Refer to "ROCKER ARMS, PUSH RODS AND VALVE LIFTERS".
	Engine oil		Drain. Refer to "CHANGING THE ENGINE OIL" in chapter 3.
1	Clutch cable	1	Disconnect.
2	Pull lever	1	Refer to "INSTALLING THE CLUTCH".
3	Pull lever spring	1	
4	Crankshaft position sensor lead	1	Disconnect.

CLUTCH

ENG

③

REMOVING THE CLUTCH

1. Remove:
 - clutch cable holder ①
 - clutch cover ②

NOTE:
Loosen each bolt 1/4 of a turn at a time, in stages and in a crisscross pattern. After all of the bolts are fully loosened, remove them.

2. Straighten the lock washer tab.
3. Loosen:
 - clutch boss nut ③

NOTE:
While holding the clutch boss ④ with the universal clutch holder ⑧, loosen the clutch boss nut.

⑧

















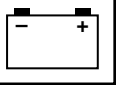

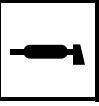

Universal clutch holder
YM-91042

4. Remove:
 - clutch boss nut ④
 - lock washer ⑤
 - clutch boss assembly ⑥

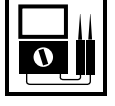
NOTE:
There is a built-in damper between the clutch boss and the clutch plate. It is not necessary to remove the wire circlip ⑦ and disassemble the built-in damper unless there is serious clutch chattering.

5 - 56

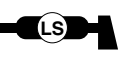
5 - 61

① GEN INFO 	② SPEC 	
③ CHK ADJ 	④ CHAS 	
⑤ ENG 	⑥ FI 	
⑦ ELEC 	⑧ TRBL SHTG 	
⑨ 	⑩ 	
⑪ 	⑫ 	
⑬ 	⑭ 	
⑮ 	⑯ 	
⑰ 	⑱ 	⑲ 
⑳ 	㉑ 	㉒ 
㉓ 	㉔ New	

EAS00009

SYMBOLS

The following symbols are not relevant to every vehicle. Symbols ① to ⑧ indicate the subject of each chapter.

- ① General information
- ② Specifications
- ③ Periodic checks and adjustments
- ④ Chassis
- ⑤ Engine
- ⑥ Fuel injection system
- ⑦ Electrical system
- ⑧ Troubleshooting

Symbols ⑨ to ⑯ indicate the following.

- ⑨ Serviceable with engine mounted
- ⑩ Filling fluid
- ⑪ Lubricant
- ⑫ Special tool
- ⑬ Tightening torque
- ⑭ Wear limit, clearance
- ⑮ Engine speed
- ⑯ Electrical data

Symbols ⑰ to ㉒ in the exploded diagrams indicate the types of lubricants and lubrication points.

- ⑰ Engine oil
- ⑱ Gear oil
- ⑲ Molybdenum-disulfide oil
- ⑳ Wheel-bearing grease
- ㉑ Lithium-soap-based grease
- ㉒ Molybdenum-disulfide grease

Symbols ㉓ to ㉔ in the exploded diagrams indicate the following.

- ㉓ Apply locking agent (LOCTITE®)
- ㉔ Replace the part

CONTENTS

SPECIFICATIONS	1
GENERAL SPECIFICATIONS	1
ENGINE SPECIFICATIONS	1
CHASSIS SPECIFICATIONS	1
ELECTRICAL SPECIFICATIONS	2
TIGHTENING TORQUES	2
CHASSIS TIGHTENING TORQUES	2
CABLE ROUTING	3
PERIODIC CHECKS AND ADJUSTMENTS	11
INTRODUCTION	11
PERIODIC MAINTENANCE CHART FOR THE EMISSION CONTROL SYSTEM	11
GENERAL MAINTENANCE AND LUBRICATION CHART	12
CHASSIS	14
ADJUSTING THE REAR SHOCK ABSORBER ASSEMBLY	14
CHASSIS	16
FRONT AND REAR BRAKES	16
REAR BRAKE MASTER CYLINDER	16
REAR SHOCK ABSORBER AND SWINGARM	18
ENGINE	22
ROCKER ARMS, PUSH RODS AND VALVE LIFTERS	22
GENERATOR AND STARTER CLUTCH	24
STATOR COIL ASSEMBLY	24

SPECIFICATIONS

GENERAL SPECIFICATIONS

Item	Standard	Limit
Model code	5PX4 (USA) 5PX5 (California) 5PX6 (CDN)	---- ---- ----

ENGINE SPECIFICATIONS

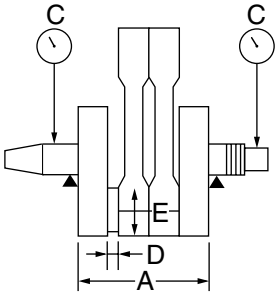
Item	Standard	Limit
Electronic fuel injection		
Model (manufacturer)	INP-732 (NIPPON INJECTOR)	----
Quantity	2	----
Crankshaft		
		
Width A	132.8 ~ 133.2 mm (5.228 ~ 5.244 in)	----
Max. runout C	----	0.04 mm (0.0016 in)
Big end side clearance D	0.320 ~ 0.474 mm (0.0126 ~ 0.0187 in)	----
Big end radial clearance E	0.037 ~ 0.074 mm (0.0015 ~ 0.0029 in)	0.09 mm (0.0035 in)
Crankshaft journal-to-crankshaft-journal bearing clearance	0.032 ~ 0.062 mm (0.0012 ~ 0.0024 in)	0.1 mm (0.0039 in)
Fuel pump		
Pump type	Electrical	----
Model (manufacturer)	5PX (MITSUBISHI)	----
Max. consumption amperage	5 A	----
Output pressure	392 ~ 588 kPa (3.92 ~ 5.88 kg/cm ² , 55.7 ~ 83.6 psi)	----

CHASSIS SPECIFICATIONS

Item	Standard	Limit
Front tire		
Tire type	Tubeless	----
Size	120/70 ZR 18 M/C (59 W) 120/70 ZR 18 (59 W)	----
Model (manufacturer)	D220F ST G (DUNLOP)/ BT020F G (BRIDGESTONE)	----

CHASSIS SPECIFICATIONS/ ELECTRICAL SPECIFICATIONS/TIGHTENING TORQUES

SPEC

Item	Standard	Limit
Tire pressure (cold) 0 ~ 90 kg (0 ~ 198 lb) 90 kg (198 lb) ~ Maximum load* High-speed riding	250 kPa (2.5 kgf/cm ² , 36 psi) 250 kPa (2.5 kgf/cm ² , 36 psi) 250 kPa (2.5 kgf/cm ² , 36 psi) * Load is the total weight of the cargo, rider, passenger and accessories.	---- ---- ----
Min. tire tread depth	----	1.0 mm (0.04 in)
Rear tire		
Tire type	Tubeless	----
Size	200/50 ZR 17 M/C (75 W) 200/50 ZR 17 (75 W)	----
Model (manufacturer)	D220 ST (DUNLOP)/ BT020R (BRIDGESTONE)	----
Tire pressure (cold) 0 ~ 90 kg (0 ~ 198 lb) 90 kg (198 lb) ~ Maximum load* High-speed riding	250 kPa (2.5 kgf/cm ² , 36 psi) 290 kPa (2.9 kgf/cm ² , 42 psi) 250 kPa (2.5 kgf/cm ² , 36 psi) * Load is the total weight of the cargo, rider, passenger and accessories.	---- ---- ----
Min. tire tread depth	----	1.0 mm (0.04 in)

ELECTRICAL SPECIFICATIONS

Item	Standard	Limit
Ignition coils		
Model (manufacturer)	J0447 (DENSO)	----
Minimum ignition spark gap	6 mm (0.24 in)	----
Primary coil resistance	1.32 ~ 1.78 Ω	----
Secondary coil resistance	12 ~ 18 kΩ	----
Charging system		
System type	AC magneto	----
Model (manufacturer)	F5PX (YAMAHA)	----
Nominal output	14 V/31 A at 5,000 r/min	----
Stator coil resistance/color	0.13 ~ 0.19 Ω/W-W	----

TIGHTENING TORQUES

CHASSIS TIGHTENING TORQUES

Item	Thread size	Tightening torque			Remarks
		Nm	m·kg	ft·lb	
Rider footrest bracket and frame	M10	48	4.8	35	
Rear fender and turn signal light bracket (upper)	M6	7	0.7	5.1	
Rear fender and turn signal light bracket (lower)	M6	9	0.9	6.5	
Canister and rider footrest bracket (For California only)	M6	9	0.9	6.5	



EB206000

CABLE ROUTING

- ① Brake hose
- ② Clutch cable
- ③ Rectifier/regulator
- ④ Rectifier/regulator lead
- ⑤ Rear brake light switch lead
- ⑥ Horn lead
- ⑦ Stator coil assembly lead

- A Fasten the rectifier/regulator lead, horn lead, and rear brake light switch lead with a plastic locking tie to the frame.
- B Fasten the stator coil assembly lead and rectifier/regulator lead with a plastic clamp.

- C Fasten the rear brake light switch lead, horn lead, and stator coil assembly lead with a plastic locking tie to the frame.
- D Fasten the stator coil assembly lead, horn lead, and rear brake light switch lead with a plastic locking tie to the frame.

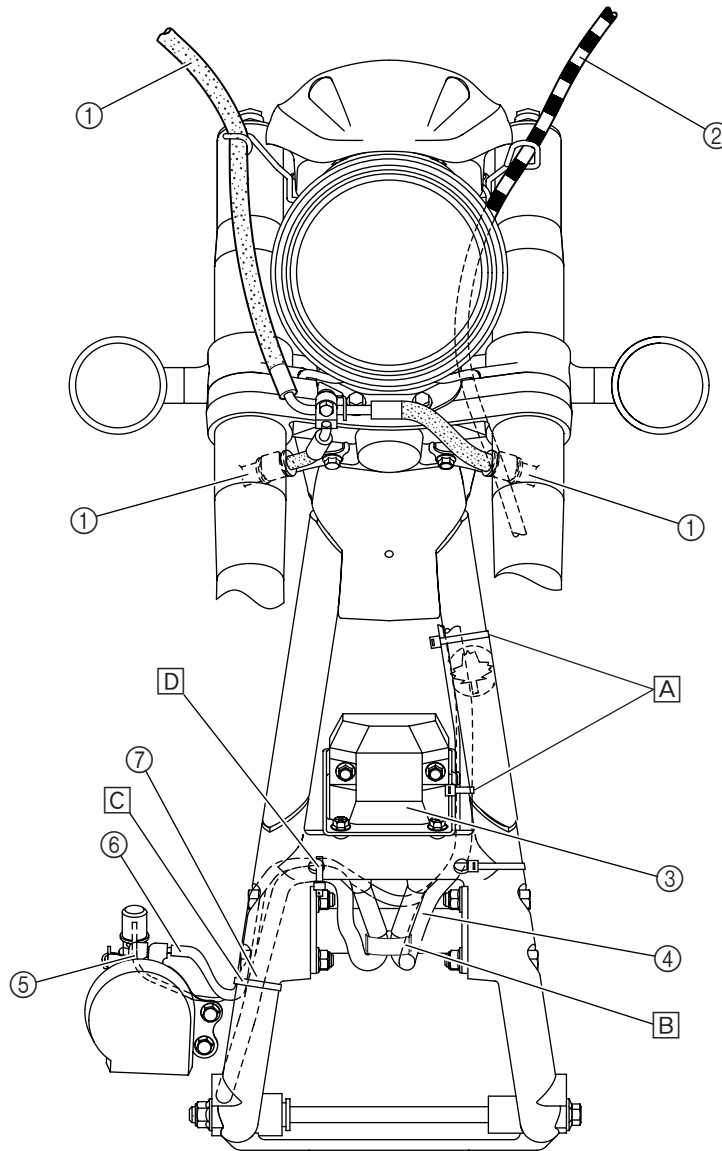



- ① Tachometer couplers
- ② Right handlebar switch coupler and speedometer couplers
- ③ Main switch coupler
- ④ Left handlebar switch couplers
- ⑤ Left and right turn signal/position light connectors

- A Secure the wire harness in the holder at the white tape on the harness.
- B Route each lead behind the headlight assembly bracket bolts.

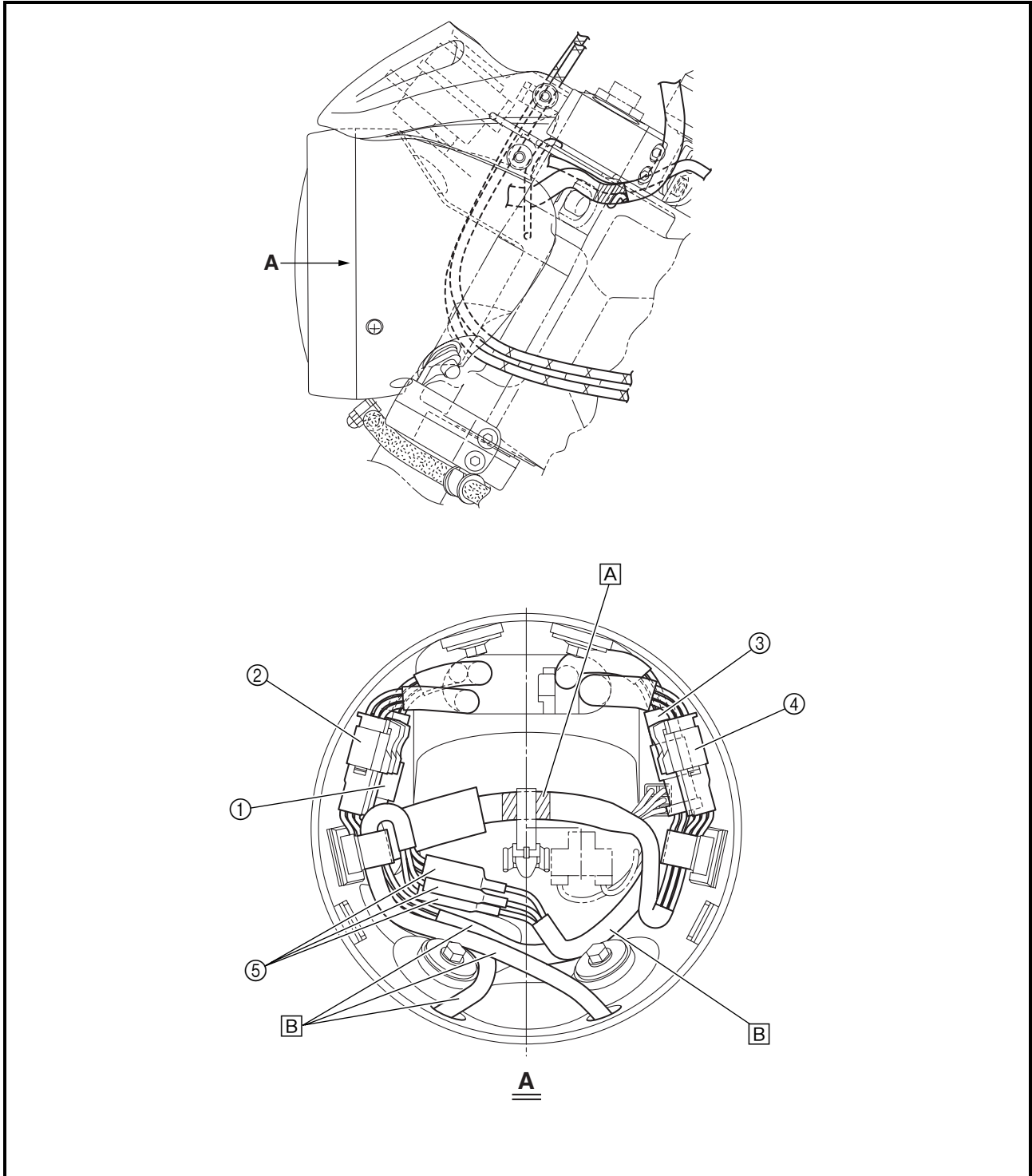



- ① Throttle cable 1 and throttle cable 2
- ② Clutch cable
- ③ Atmospheric pressure sensor
- ④ Spark plug cap (ignition coil 1-L spark plug lead)
- ⑤ Horn lead
- ⑥ Crankshaft position sensor lead
- ⑦ Horn 2
- ⑧ Sidestand switch lead
- ⑨ Starter motor lead
- ⑩ Spark plug cap (ignition coil 2-L spark plug lead)
- ⑪ Rear brake light switch

- A Pass throttle cable 1 and throttle cable 2 through the cable guide, and then fasten them with a plastic holder.
- B Fasten the engine stop switch lead, horn lead, and oil temperature sensor lead with a plastic locking tie.
- C Fasten the sidestand switch lead, starter motor lead, crankshaft position sensor lead, decompression solenoid lead, cylinder identification sensor lead, speed sensor lead, and neutral switch lead with a plastic locking tie.

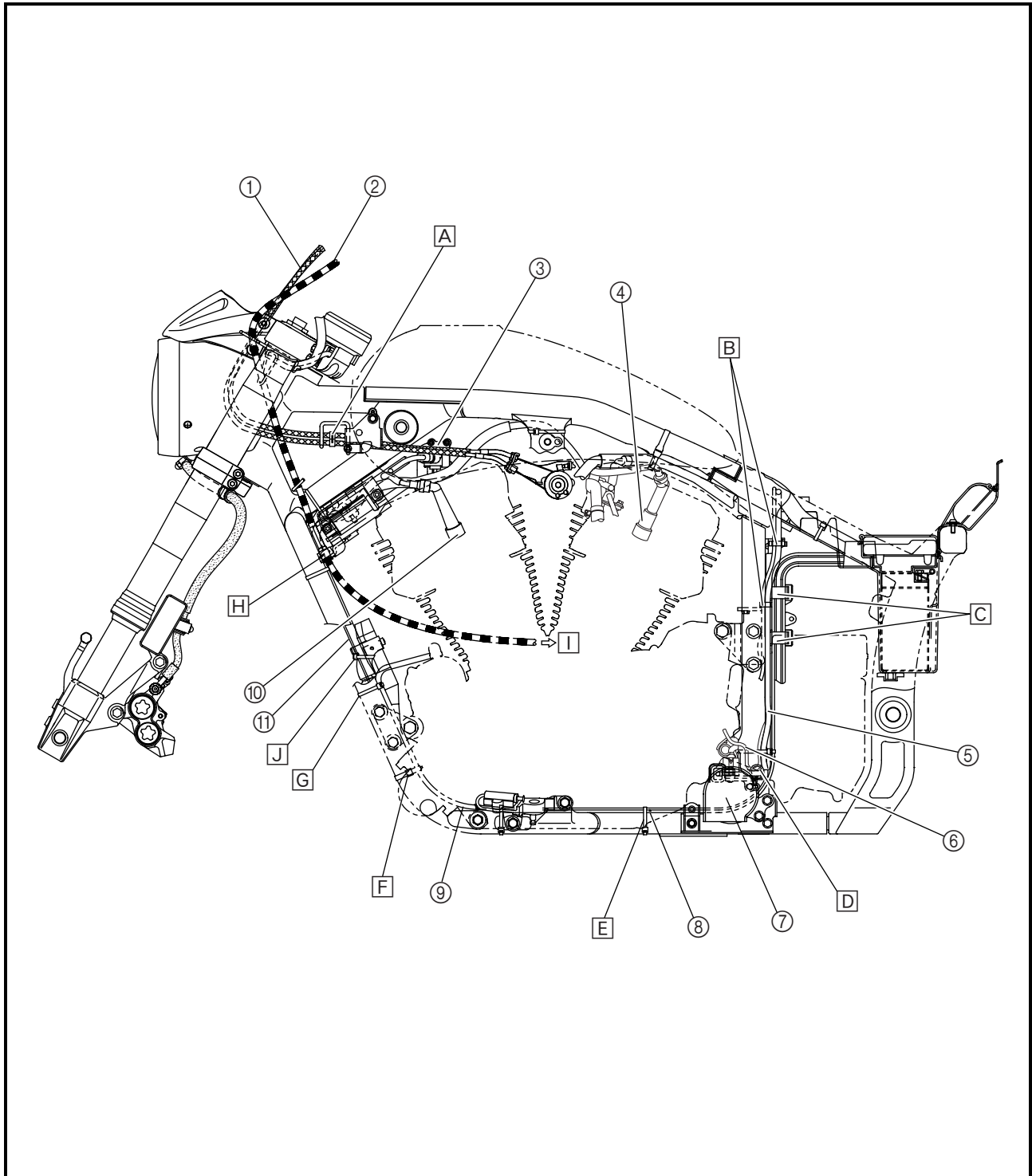



- D Fasten the engine stop switch lead, crankshaft position sensor lead, and horn lead with a plastic locking tie.
- E Fasten the starter motor lead and side stand switch lead with a plastic locking tie to the frame.
- F Fasten the starter motor lead, fuel tank drain hose, and fuel tank/air filter breather hose with a plastic band to the frame.
- Be sure not to pinch the fuel tank drain hose or the fuel tank/air filter breather hose.
- G Fasten the starter motor lead with a plastic locking tie.
- H Clamp the clutch cable between the locknut and washer with a plastic clamp.
- I To the engine.
- J Fasten the rear brake light switch with a plastic locking tie.

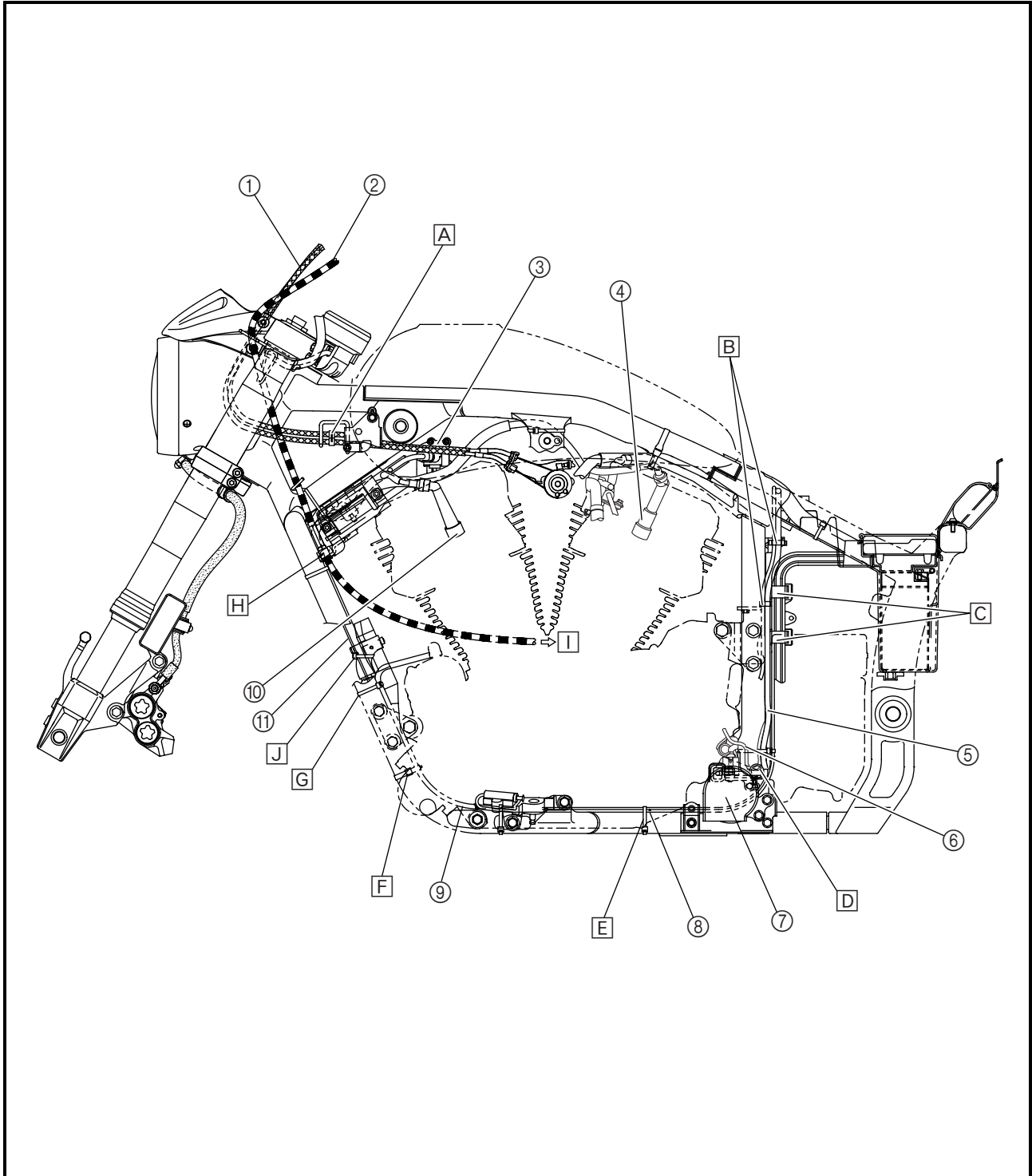



- ① Ignition coil 1
- ② Atmospheric pressure sensor lead
- ③ Ignition coil 2
- ④ Ignition coil 2 lead
- ⑤ Rear brake light switch coupler
- ⑥ Rectifier/regulator lead and horn lead
- ⑦ Linear control valve lead
- ⑧ Ignition coil 1 lead
- ⑨ Fuel return hose
- ⑩ Fuel inlet hose

- A** To the rectifier/regulator, horn 1, and rear brake light switch.
- B** 30 ~ 50 degrees
- C** 40 ~ 60 degrees

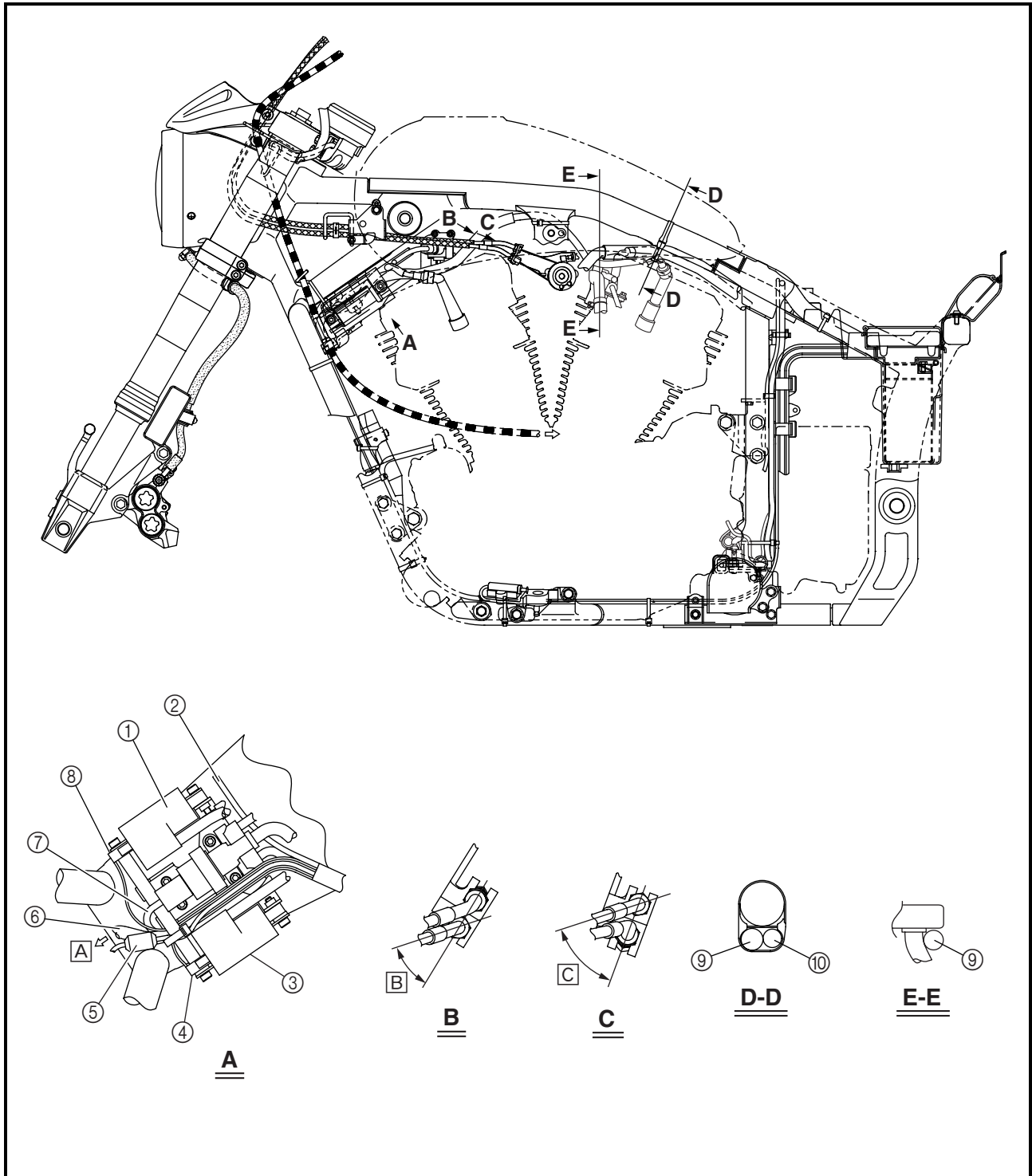



- | | | |
|--|--|-------------------------------------|
| ① Oil temperature sensor | ⑨ Intake air pressure sensor 2 | ⑱ Ignition coil 1-R spark plug lead |
| ② Fuel hose | ⑩ Throttle cables | ⑲ Lean angle cut-off switch lead |
| ③ Spark plug cap (ignition coil 1-R spark plug lead) | ⑪ Brake hose | ⑳ Crankshaft position sensor lead |
| ④ Injector lead | ⑫ Spark plug cap (ignition coil 2-R spark plug lead) | ㉑ Sidestand switch lead |
| ⑤ Throttle position sensor lead | ⑬ Engine temperature sensor lead | ㉒ Starter motor lead |
| ⑥ Intake air pressure sensor 1 | ⑭ Stator coil lead | ㉓ Horn 2 lead |
| ⑦ Intake air temperature sensor coupler | ⑮ Neutral switch lead | ㉔ Oil temperature sensor lead |
| ⑧ Intake air pressure sensor lead | ⑯ Speed sensor lead | |
| | ⑰ Main wire harness | |

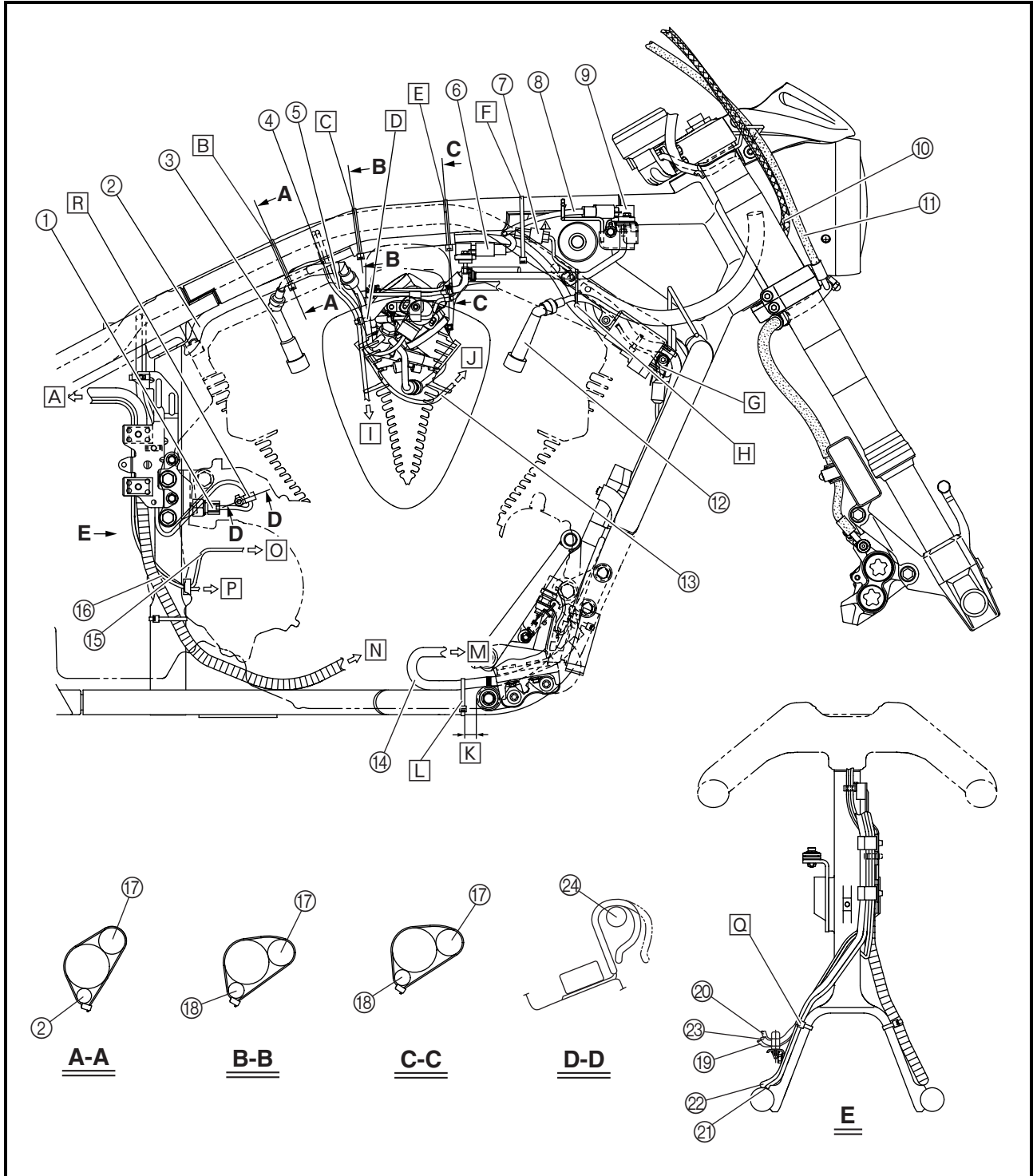



- A To the battery box.
- B Fasten the main wire harness and fuel hose with a plastic locking tie to the frame.
- C Fasten the main wire harness and spark plug lead #3 with a plastic locking tie to the frame.
- D Fasten the throttle position sensor lead, engine temperature sensor lead, and injector lead with a plastic locking tie to the fuel delivery pipe.
- E Fasten the main wire harness and spark plug lead #3 with a plastic locking tie.

- F Fasten the main wire harness, intake air pressure sensor lead #2, ignition coil 1-R spark plug lead, and intake air temperature sensor coupler with a plastic locking tie.
- G Fasten the rear brake light switch lead and ignition coil lead #2 with a plastic band.
- H Fasten the main wire harness and intake vacuum hose with a plastic locking tie.

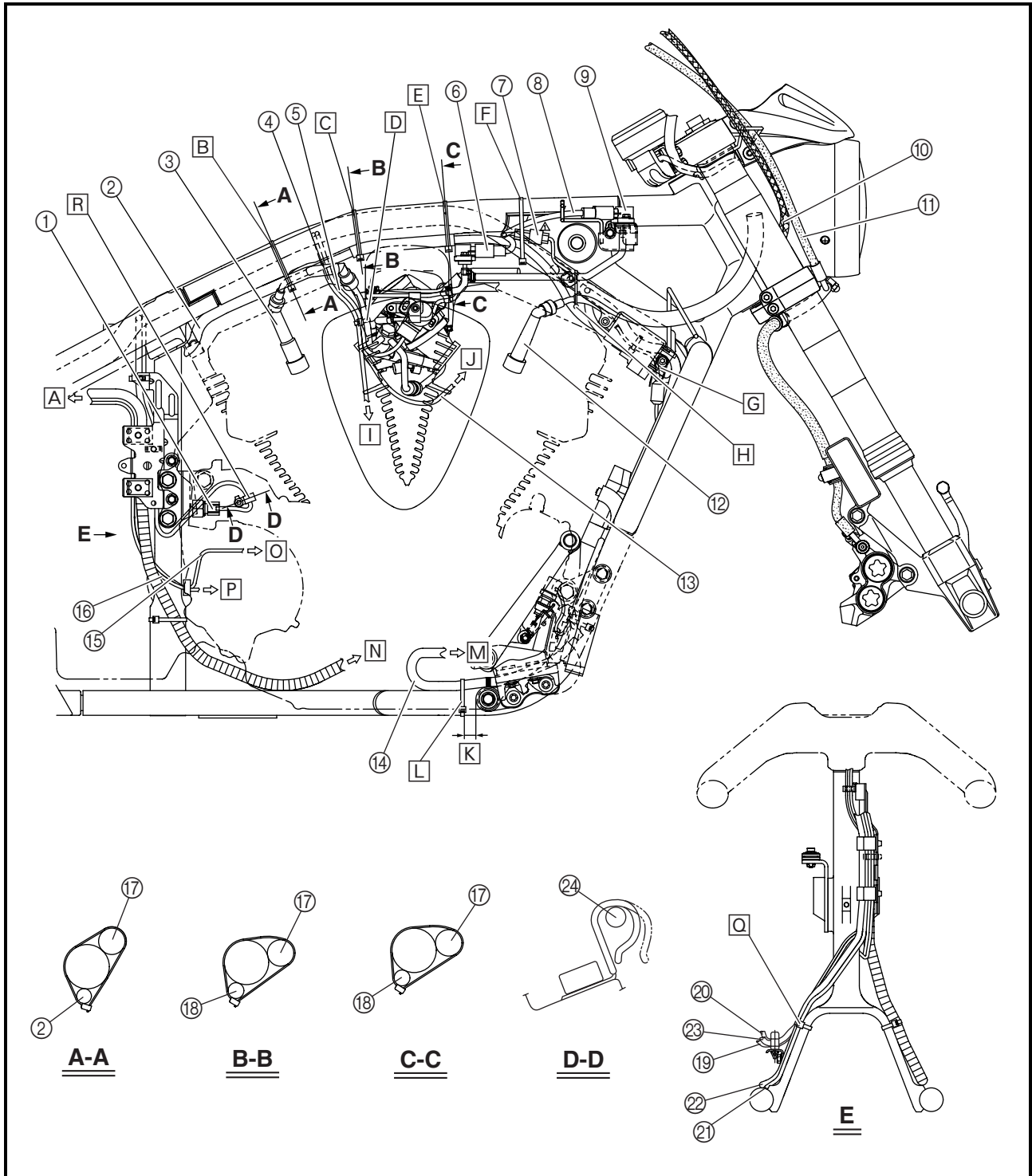



- I To the injector sub lead.
- J To the engine temperature sensor.
- K 10 ~ 30 mm (0.4 ~ 1.2 in)
- L Position the gray mark on the stator coil lead at the center of the bolt, and then fasten it with a plastic locking tie.
- M To the stator coil.
- N To the decompression solenoid and cylinder identification sensor.
- O To the neutral switch.

- P To the speed sensor.
- Q Fasten the crankshaft position sensor lead, side-stand switch lead, lean angle cut-off switch lead, starter motor lead, and horn lead with a plastic locking tie.
- R Fasten the oil temperature sensor lead with the lead holder.

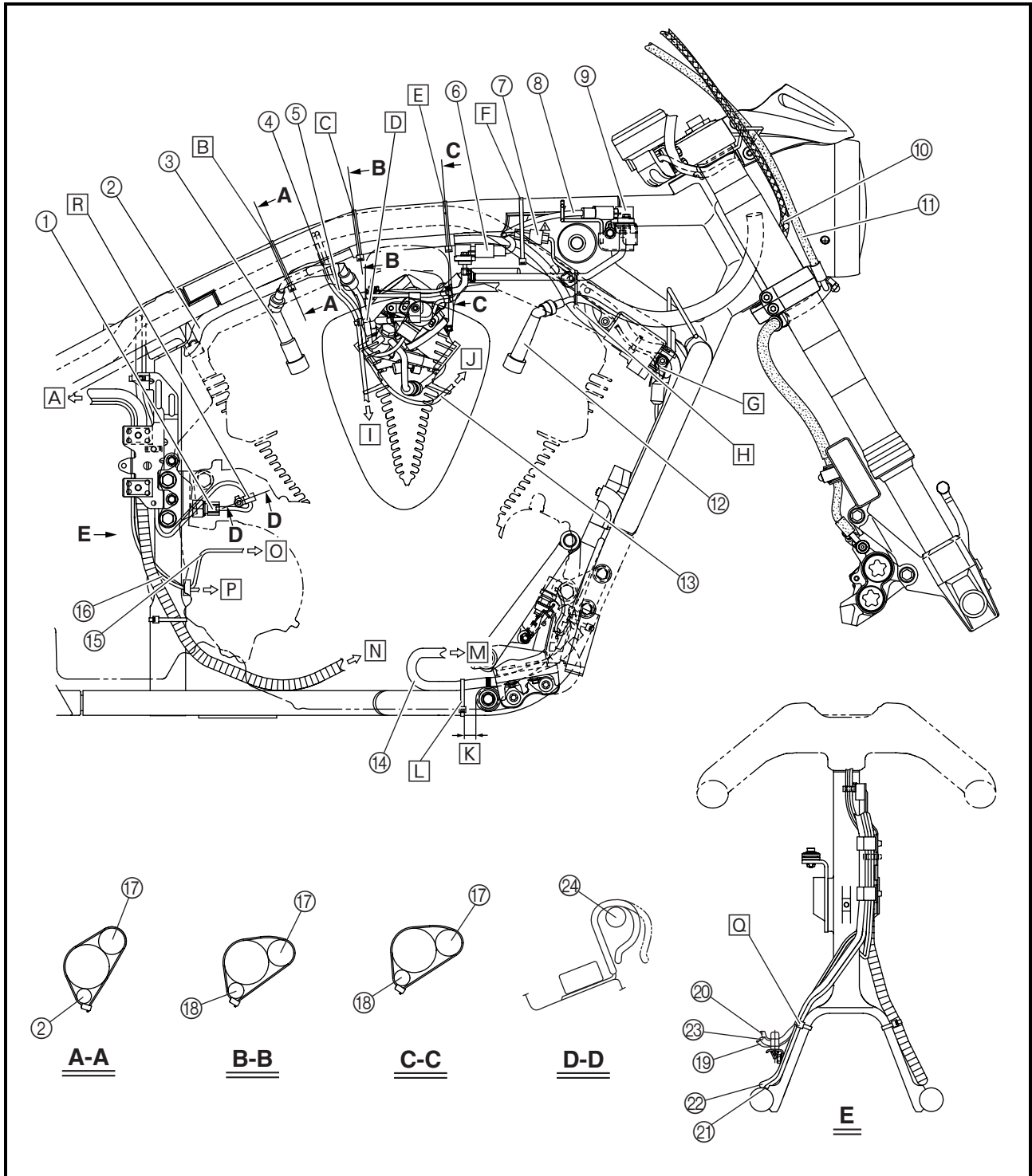

INTRODUCTION/PERIODIC MAINTENANCE CHART FOR THE EMISSION CONTROL SYSTEM



EAS00036

PERIODIC CHECKS AND ADJUSTMENTS

INTRODUCTION

This chapter includes all information necessary to perform recommended checks and adjustments. If followed, these preventive maintenance procedures will ensure more reliable vehicle operation, a longer service life and reduce the need for costly overhaul work. This information applies to vehicles already in service as well as to new vehicles that are being prepared for sale. All service technicians should be familiar with this entire chapter.

PERIODIC MAINTENANCE CHART FOR THE EMISSION CONTROL SYSTEM

No.	ITEM	ROUTINE	INITIAL	ODOMETER READINGS				
			600 mi (1,000 km) or 1 month	4,000 mi (7,000 km) or 6 months	8,000 mi (13,000 km) or 12 months	12,000 mi (19,000 km) or 18 months	16,000 mi (25,000 km) or 24 months	20,000 mi (31,000 km) or 30 months
1	* Valve clearance	<ul style="list-style-type: none"> • Check valve clearance when engine is cold. • Adjust if necessary. 	Every 16,000 mi (25,000 km)					
2	* Spark plugs	<ul style="list-style-type: none"> • Check condition. • Adjust gap and clean. • Replace at 8,000 mi (13,000 km) or 12 months and thereafter every 8,000 mi (13,000 km) or 12 months. 		√	Replace.	√	Replace.	√
3	* Crankcase ventilation system	<ul style="list-style-type: none"> • Check ventilation hose for cracks or damage. • Replace if necessary. 		√	√	√	√	√
4	* Fuel line	<ul style="list-style-type: none"> • Check fuel hose for cracks or damage. • Replace if necessary. 		√	√	√	√	√
5	* Exhaust system	<ul style="list-style-type: none"> • Check for leakage. • Tighten if necessary. • Replace gasket(s) if necessary. 		√	√	√	√	√
6	* Electronic fuel injection	<ul style="list-style-type: none"> • Check and adjust engine idle speed and synchronization. • Adjust cable free play. 	√	√	√	√	√	√
7	* Evaporative Emission control system (For California only)	<ul style="list-style-type: none"> • Check control system for damage. • Replace if necessary. 				√		√

* Since these items require special tools, data and technical skills, have a Yamaha dealer perform the service.

GENERAL MAINTENANCE AND LUBRICATION CHART



GENERAL MAINTENANCE AND LUBRICATION CHART

No.	ITEM	ROUTINE	TYPE	INITIAL	ODOMETER READINGS					
				600 mi (1,000 km) or 1 month	4,000 mi (7,000 km) or 6 months	8,000 mi (13,000 km) or 12 months	12,000 mi (19,000 km) or 18 months	16,000 mi (25,000 km) or 24 months	20,000 mi (31,000 km) or 30 months	
1	Engine oil	• Change.	—	√	√	√	√	√	√	
2	* Engine oil filter cartridge	• Replace.	—	√		√		√		
3	* Air filter elements	• Check condition and for damage. • Replace if necessary.	—		√	√	√	√	√	
4	* Front brake	• Check operation and fluid leakage. • Correct if necessary.	—	√	√	√	√	Replace brake fluid.	√	
5	* Rear brake	• Check operation and fluid leakage. • Correct if necessary.	—	√	√	√	√	Replace brake fluid.	√	
6	* Clutch	• Check operation and free play. • Correct if necessary.	—	√	√	√	√	√	√	
7	* Transfer case oil	• Check vehicle for leakage. • Replace every 16,000 mi (25,000 km) or 24 months.	SAE 80 API “GL-4” hypoid gear oil	Change.		Check.		Change.		
8	* Throttle grip housing and cable	• Check operation and free play. • Adjust the throttle cable free play if necessary. • Lubricate the throttle grip housing and cable.	—		√	√	√	√	√	
9	* Control cables	• Apply chain lube thoroughly.	Yamaha Chain and Cable Lube or engine oil (API SE) 10W-30	√	√	√	√	√	√	
10	* Rear arm pivot bearing	• Check bearing assembly for looseness. • Moderately repack every 16,000 mi (25,000 km) or 24 months.	Lithium-soap-based grease			√		Repack.		
11	Brake and clutch lever pivot shafts	• Lubricate. • Apply grease lightly.	Lithium-soap-based grease (all-purpose grease)		√	√	√	√	√	
12	Brake pedal and shift pedal shafts	• Lubricate. • Apply grease lightly.	Lithium-soap-based grease (all-purpose grease)		√	√	√	√	√	
13	* Sidestand pivot	• Check operation and lubricate. • Apply grease lightly.	Lithium-soap-based grease (all-purpose grease)		√	√	√	√	√	
14	* Sidestand switch	• Check and clean or replace if necessary.	—	√	√	√	√	√	√	
15	* Front fork	• Check operation and for leakage.	—		√	√	√	√	√	
16	* Steering bearings	• Check bearing assembly for looseness. • Moderately repack every 16,000 mi (25,000 km) or 24 months.	Lithium-soap-based grease (all-purpose grease)		√	√	√	Repack.	√	

GENERAL MAINTENANCE AND LUBRICATION CHART



No.	ITEM	ROUTINE	TYPE	INITIAL	ODOMETER READINGS				
				600 mi (1,000 km) or 1 month	4,000 mi (7,000 km) or 6 months	8,000 mi (13,000 km) or 12 months	12,000 mi (19,000 km) or 18 months	16,000 mi (25,000 km) or 24 months	20,000 mi (31,000 km) or 30 months
17	* Wheel bearings	• Check bearings for smooth rotation.	—		√	√	√	√	√
18	* Rear suspension link pivots	• Lubricate. • Apply grease lightly.	Lithium-soap-based grease					√	
19	* Drive belt	• Check belt tension. • Adjust if necessary.	—	√	Every 2,500 mi (4,000 km)				

* Since these items require special tools, data and technical skills, have a Yamaha dealer perform the service.

NOTE: _____

From 24,000 mi (37,000 km) or 36 months, repeat the maintenance intervals starting from 4,000 mi (7,000 km) or 6 months.

NOTE: _____

- Air filters
 - This model's air filters are equipped with disposable oil-coated paper elements, which must not be cleaned with compressed air to avoid damaging them.
 - The air filter elements need to be replaced more frequently when riding in unusually wet or dusty areas.
- Hydraulic brake service
 - After disassembling the brake master cylinders and calipers, always change the fluid. Regularly check the brake fluid levels and fill the reservoirs as required.
 - Every two years replace the internal components of the brake master cylinders and calipers, and change the brake fluid.
 - Replace the brake hoses every four years and if cracked or damaged.

CHASSIS

EAS00156

ADJUSTING THE REAR SHOCK ABSORBER ASSEMBLY

⚠ WARNING

Securely support the motorcycle so that there is no danger of it falling over.

Spring preload

CAUTION:

Never go beyond the maximum or minimum adjustment positions.

1. Adjust:
 - spring preload

NOTE:

Adjust the spring preload with the special wrench.

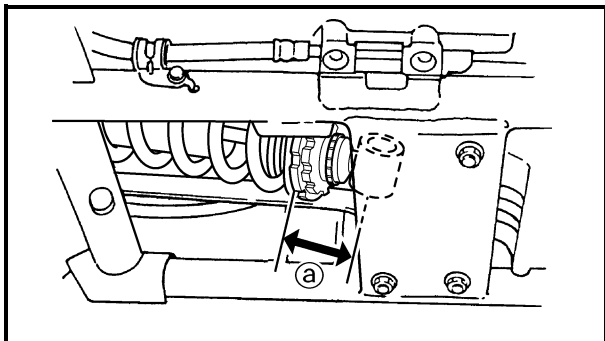
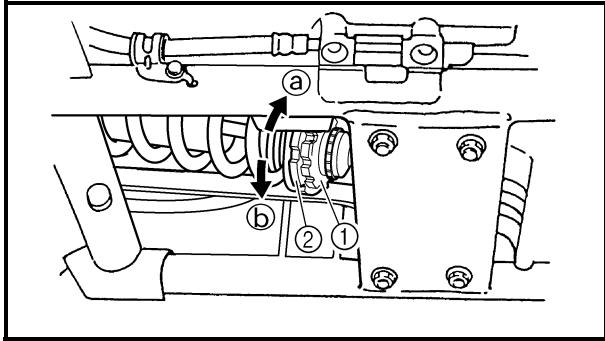

- a. Loosen the locknut ①.
- b. Turn the spring preload adjusting nut ② in direction ① or ②.

Direction ①	Spring preload is increased (suspension is harder).
Direction ②	Spring preload is decreased (suspension is softer).

Adjusting positions ① Minimum: 52 mm (2.05 in) Standard: 54 mm (2.13 in) Maximum: 63 mm (2.48 in)

CAUTION:

Never turn the spring preload adjusting nut beyond the maximum or minimum setting.



ADJUSTING THE REAR SHOCK ABSORBER ASSEMBLY

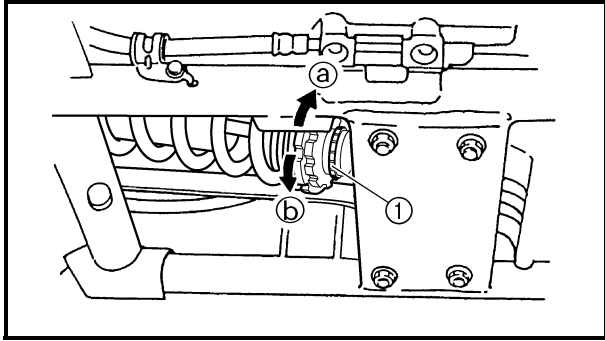

Rebound damping

CAUTION:

Never go beyond the maximum or minimum adjustment positions.

1. Adjust:
 - rebound damping

a. Turn the adjusting knob ① in direction ② or ③.

Direction ②	Rebound damping is increased (suspension is harder).
Direction ③	Rebound damping is decreased (suspension is softer).

Adjusting positions
Minimum: 20 clicks out*
Standard: 10 clicks out*
Maximum: 3 clicks out*
 * from the fully turned-in position

CHASSIS

FRONT AND REAR BRAKES

REAR BRAKE MASTER CYLINDER

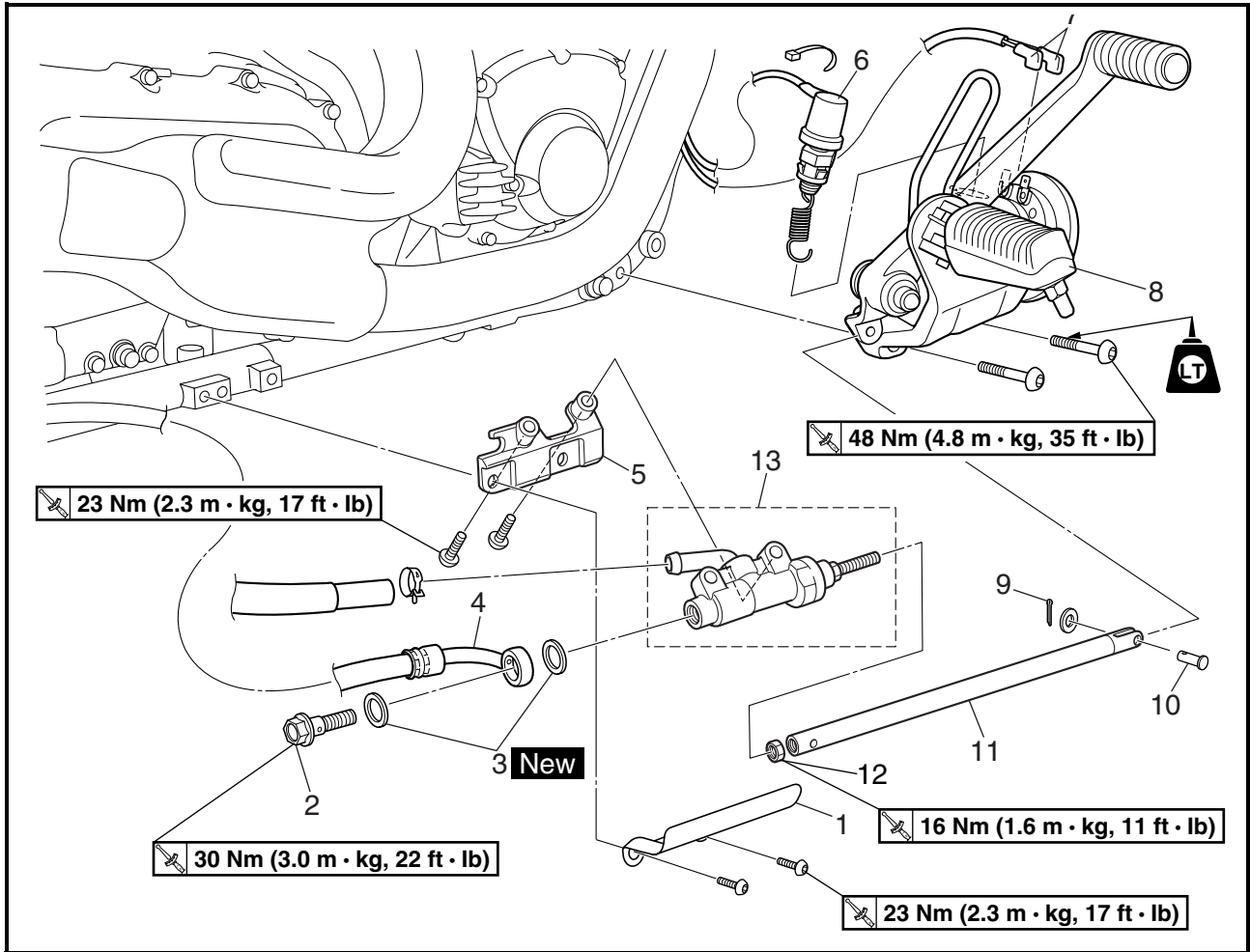

Order	Job/Part	Q'ty	Remarks
	Removing the rear brake master cylinder		Remove the parts in the order listed.
1	Brake master cylinder cover	1	Refer to "REMOVING THE REAR BRAKE MASTER CYLINDER" and "ASSEMBLING AND INSTALLING THE REAR BRAKE MASTER CYLINDER" in chapter 4. (Manual No.: 5PX-28197-10)
2	Union bolt	1	
3	Copper washer	2	
4	Brake hose	1	
			Disconnect.
5	Brake master cylinder bracket	1	
6	Rear brake light switch	1	
7	Horn 1 connector	2	Disconnect.
8	Rider footrest assembly (right)	1	

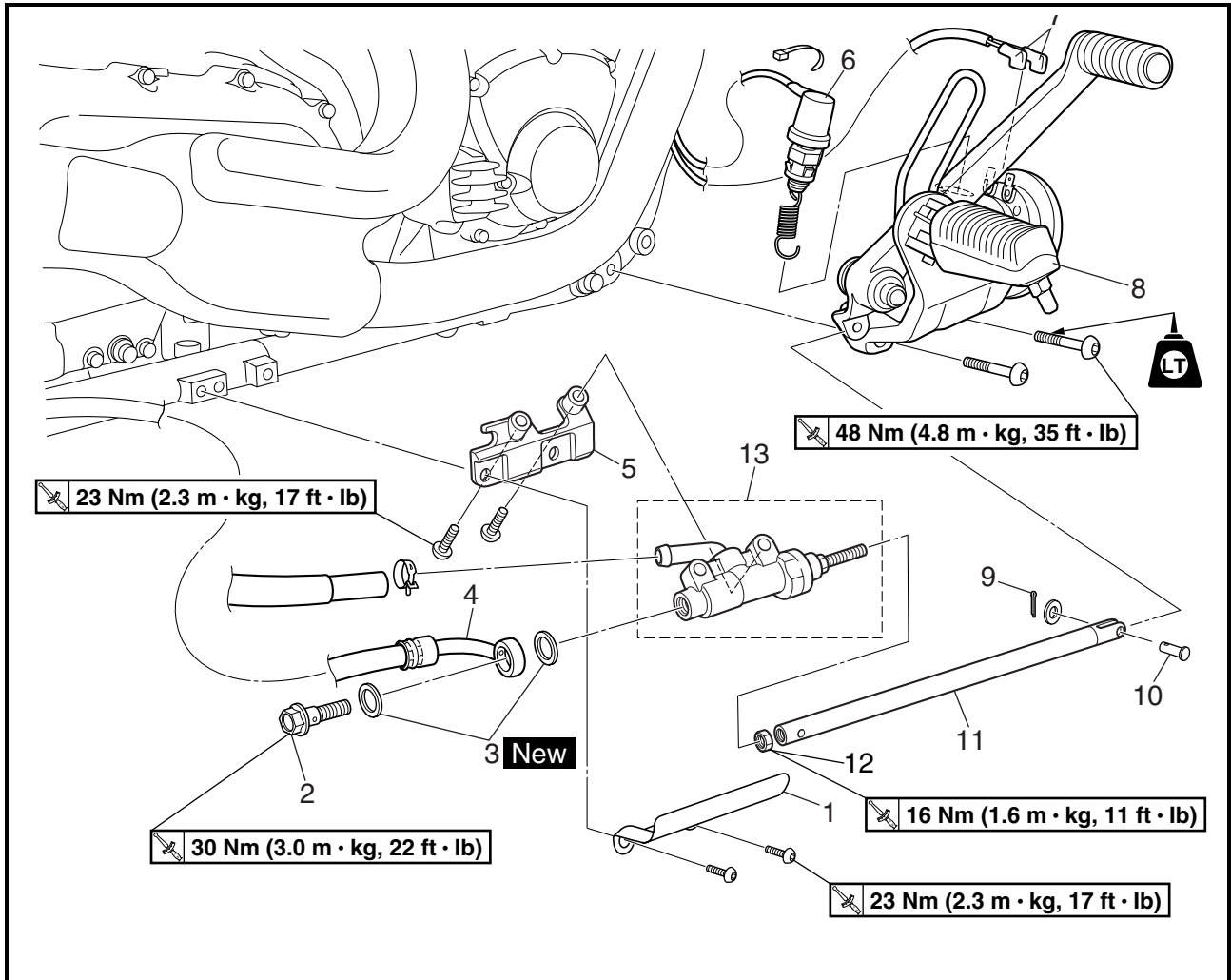

Order	Job/Part	Q'ty	Remarks
9	Cotter pin	1	For installation, reverse the removal procedure.
10	Pin	1	
11	Brake rod	1	
12	Locknut	1	
13	Brake master cylinder	1	

REAR SHOCK ABSORBER AND SWINGARM

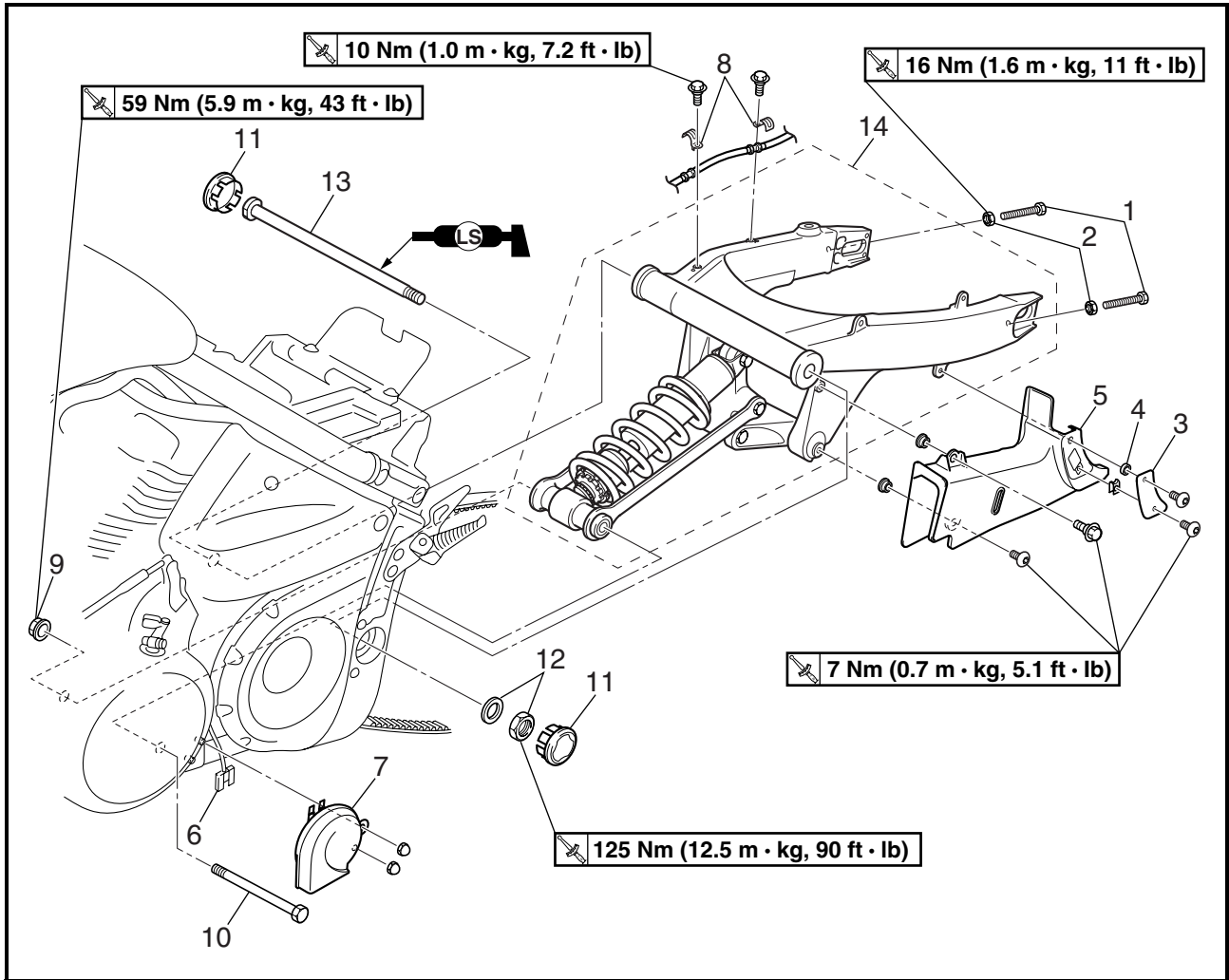

Order	Job/Part	Q'ty	Remarks
	Removing the rear shock absorber and swingarm		Remove the parts in the order listed.
	Rear brake master cylinder bracket		Refer to "FRONT AND REAR BRAKES" in chapter 4. (Manual No.: 5PX-28197-10)
	Rear exhaust pipe		Refer to "ENGINE" in chapter 5. (Manual No.: 5PX-28197-10)
	Rear wheel		Refer to "REAR WHEEL, BRAKE DISC, AND REAR WHEEL PULLEY" in chapter 4. (Manual No.: 5PX-28197-10)
1	Adjusting bolt	2	
2	Locknut	2	
3	Lower drive belt cover plate	1	
4	Spacer	1	
5	Lower drive belt cover	1	
6	Horn 2 coupler	1	Disconnect.
7	Horn 2	1	

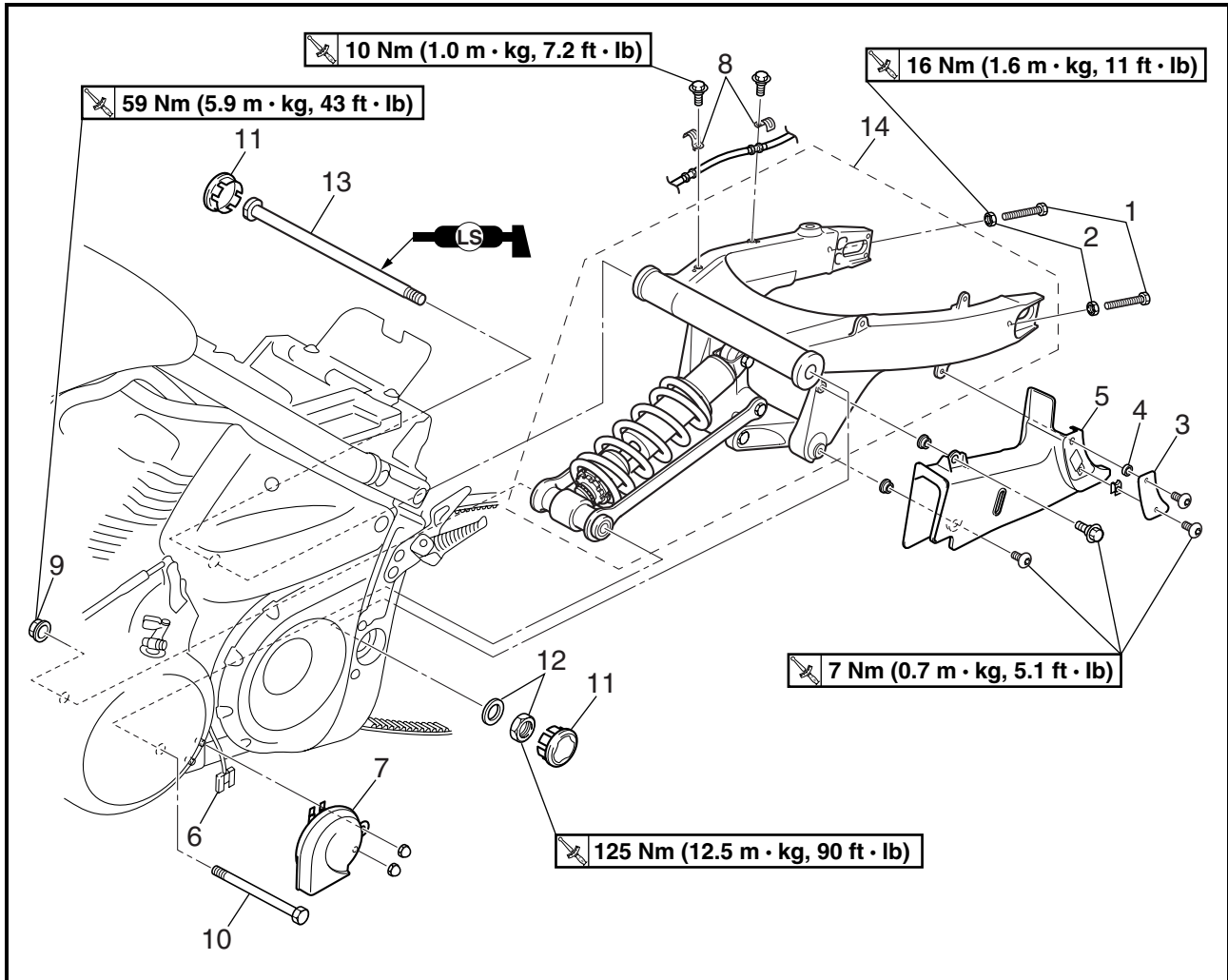

Order	Job/Part	Q'ty	Remarks
8	Brake hose holder	2	Refer to "REMOVING THE REAR SHOCK ABSORBER AND SWINGARM" in chapter 4 (Manual No.: 5PX-28197-10) and "INSTALLING THE REAR SHOCK ABSORBER AND SWINGARM" in chapter 4. (Manual No.: 5PX-28197-10)
9	Self-locking nut	1	
10	Bolt (shock absorber-connecting arm-frame)	1	
11	Cover (left and right)	2	
12	Pivot shaft nut/washer	1/1	
13	Pivot shaft	1	
14	Rear shock absorber and swingarm assembly	1	
			For installation, reverse the removal procedure.

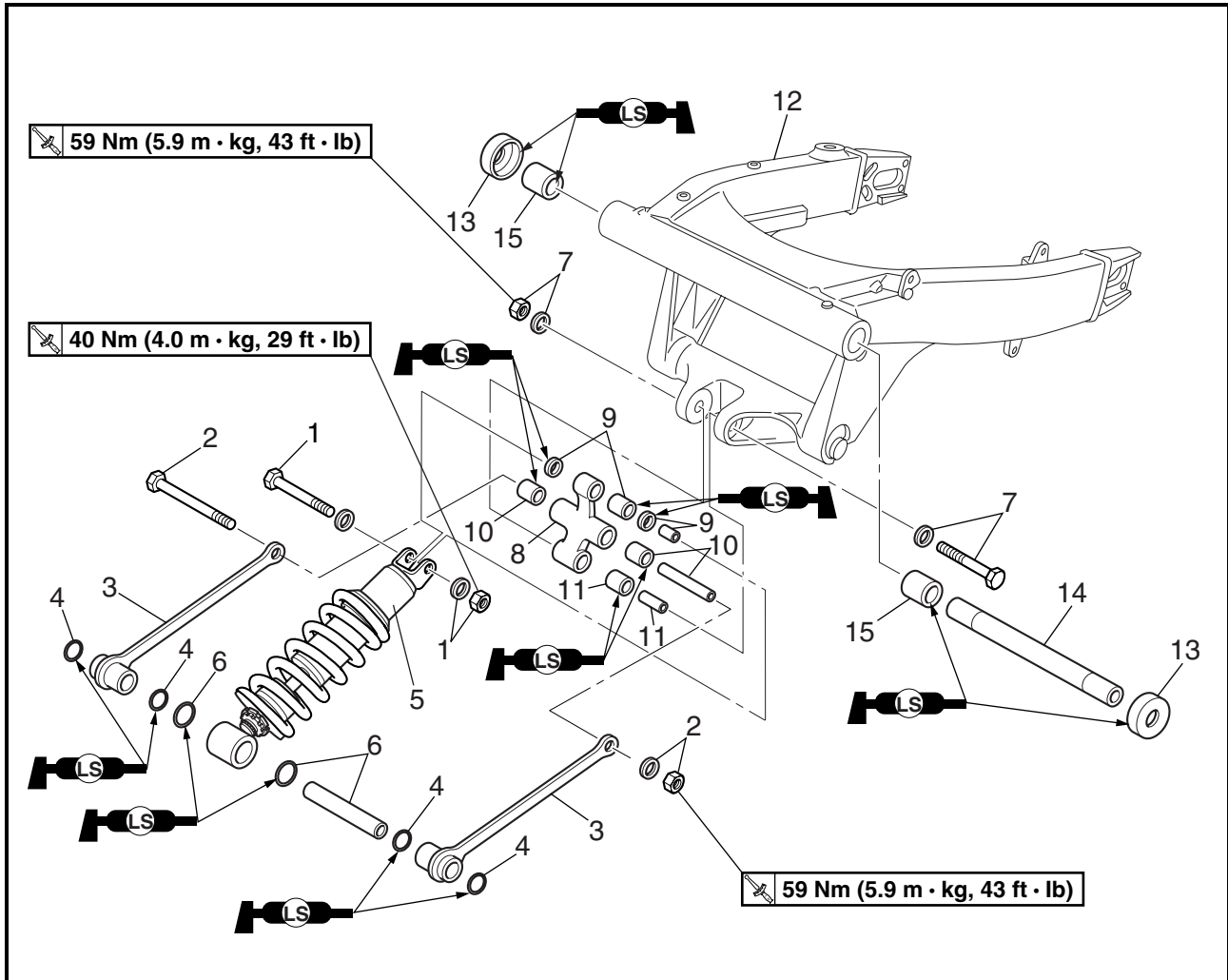

Order	Job/Part	Q'ty	Remarks
	Removing the rear shock absorber and swingarm		Remove the parts in the order listed.
1	Self-locking nut/washer/bolt	1/1/1	Bolt ℓ = 100 mm (3.94 in)
2	Self-locking nut/washer/bolt	1/1/1	Bolt ℓ = 124 mm (4.88 in)
3	Connecting arm	2	
4	O-ring	4	
5	Rear shock absorber	1	
6	Spacer/O-ring	1/2	
7	Self-locking nut/washer/bolt	1/2/1	Bolt ℓ = 77 mm (3.03 in)
8	Relay arm	1	
9	Spacer/oil seal/bearing	1/2/1	Refer to "INSTALLING THE REAR SHOCK ABSORBER AND SWINGARM" in chapter 4. (Manual No.: 5PX-28197-10)
10	Spacer/bearing	1/2	
11	Spacer/bearing	1/1	

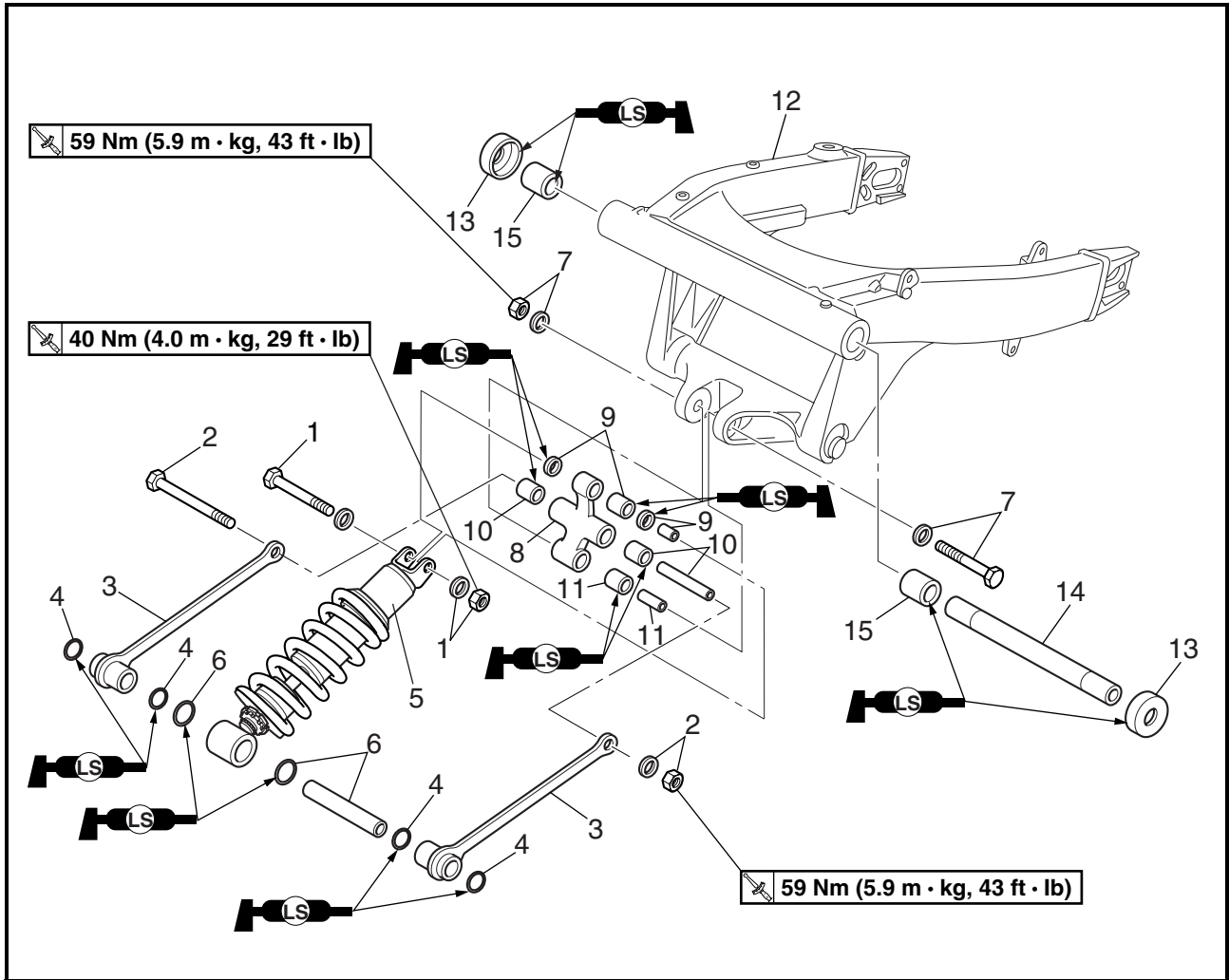

Order	Job/Part	Q'ty	Remarks
12	Swingarm	1	For installation, reverse the removal procedure.
13	Dust cover	2	
14	Spacer	1	
15	Bearing	2	



ENGINE

ROCKER ARMS, PUSH RODS AND VALVE LIFTERS

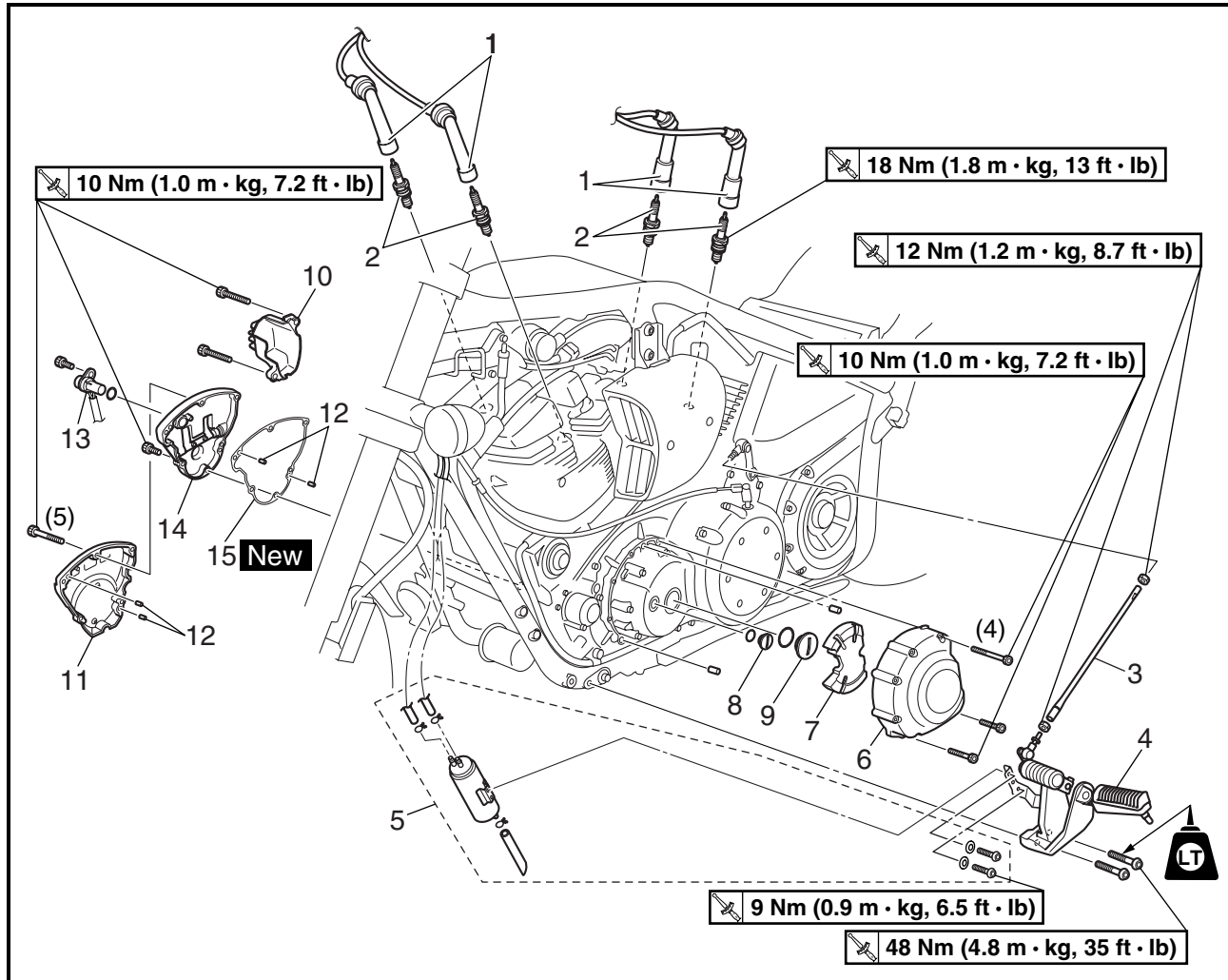

Order	Job/Part	Q'ty	Remarks
	Removing the engine left side cover and camshaft sprocket cover Seat/fuel tank/silencer air filter case		Remove the parts in the order listed. Refer to "SEAT AND SIDE COVERS", "FUEL TANK" and "SILENCER AIR FILTER CASE" in chapter 3. (Manual No.: 5PX-28197-10)
	Muffler/exhaust pipes		Refer to "ENGINE" in chapter 5. (Manual No.: 5PX-28197-10)
	Engine oil		Drain. Refer to "CHANGING THE ENGINE OIL" in chapter 3 (Manual No.: 5PX-28197-10).
1	Spark plug cap	2/2	Disconnect.
2	Spark plug	4	Refer to "INSTALLING THE CAMSHAFT SPROCKET COVER AND ENGINE LEFT SIDE COVER" in chapter 5. (Manual No.: 5PX-28197-10)
3	Shift rod	1	
4	Rider footrest assembly (left)	1	
5	Canister	1	

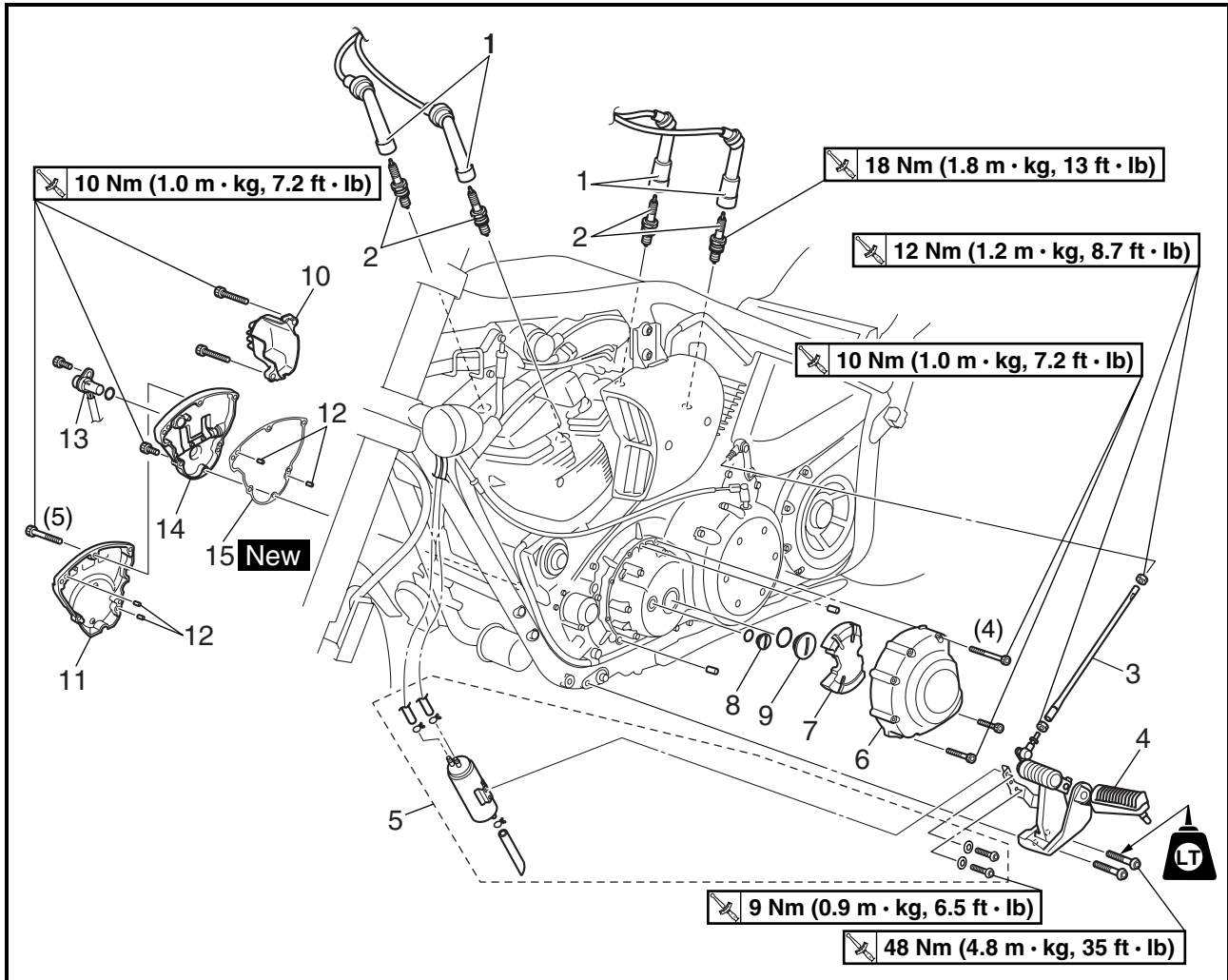

Order	Job/Part	Q'ty	Remarks
6	Engine left side cover	1	Refer to "INSTALLING THE CAMSHAFT SPROCKET COVER AND ENGINE LEFT SIDE COVER" in chapter 5. (Manual No.: 5PX-28197-10)
7	Rubber damper	1	
8	Timing mark accessing screw	1	
9	Crankshaft end cover	1	
10	Decompression solenoid cover	1	
11	Camshaft sprocket cover 1	1	
12	Dowel pin	2	
13	Cylinder identification sensor	1	
14	Camshaft sprocket cover 2	1	For installation, reverse the removal procedure
15	Camshaft sprocket cover gasket	1	



EAS00341

GENERATOR AND STARTER CLUTCH



STATOR COIL ASSEMBLY

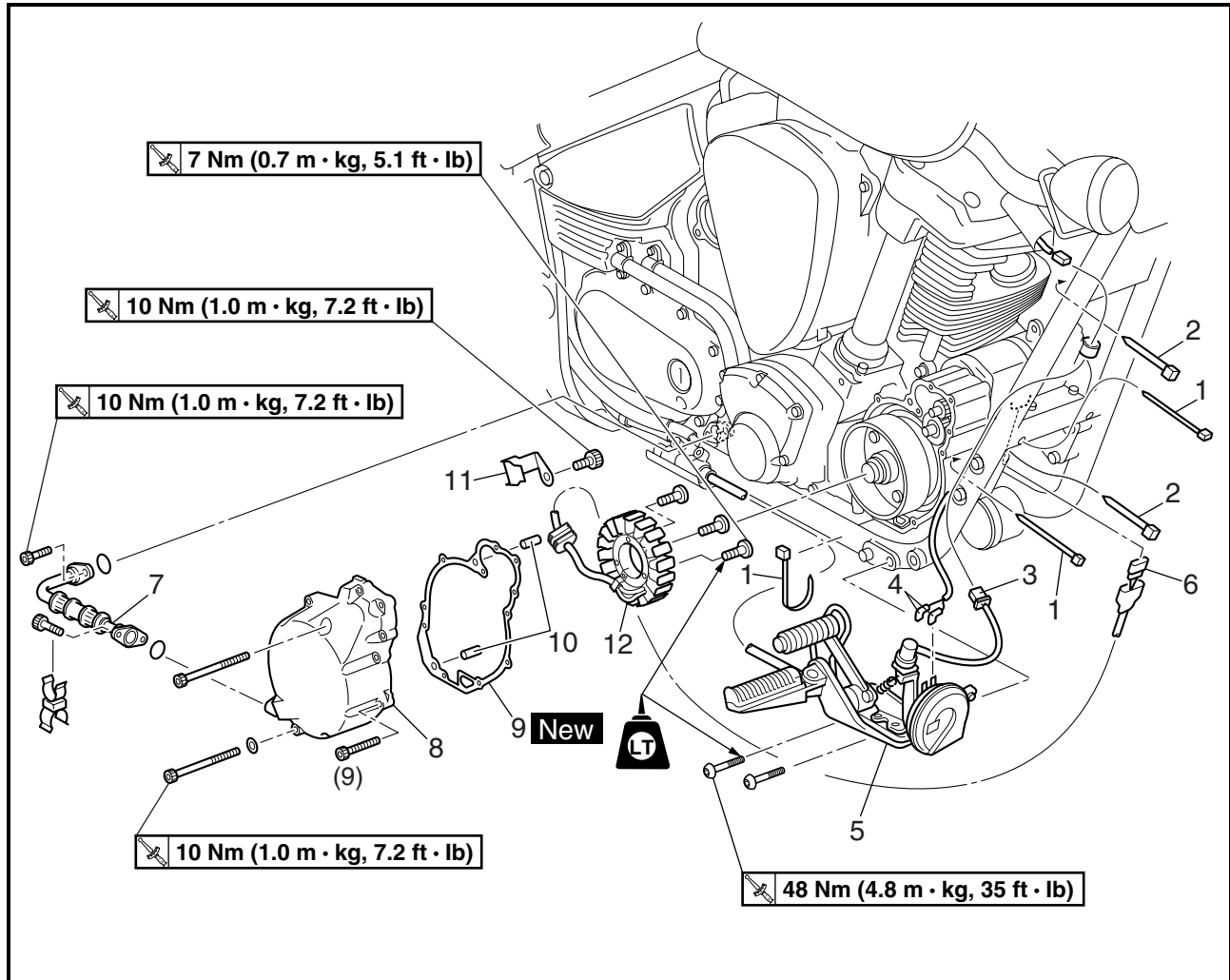

Order	Job/Part	Q'ty	Remarks
	Removing the stator coil assembly		Remove the parts in the order listed.
	Muffler/exhaust pipes		Refer to "ENGINE" in chapter 5. (Manual No.: 5PX-28197-10)
	Engine oil		Drain. Refer to "CHANGING THE ENGINE OIL" in chapter 3. (Manual No.: 5PX-28197-10)
1	Plastic locking tie	3	
2	Plastic band	2	
3	Rear brake light switch coupler	1	Disconnect.
4	Horn 1 connectors	2	
5	Rider footrest assembly (right)	1	
6	Stator coil assembly coupler	1	Disconnect.
7	Oil delivery pipe	1	

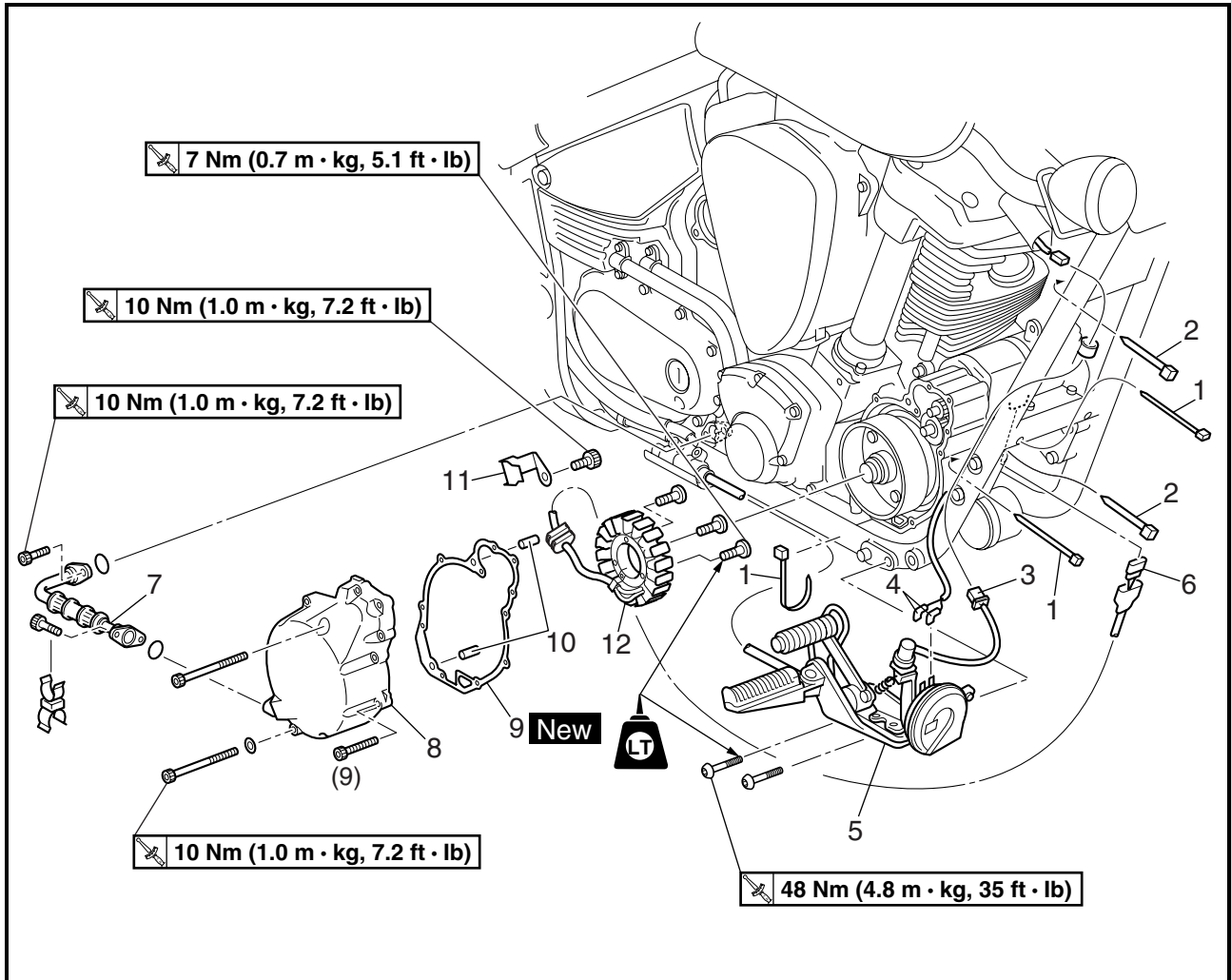

Order	Job/Part	Q'ty	Remarks
8	Generator cover	1	For installation, reverse the removal procedure.
9	Generator cover gasket	1	
10	Dowel pin	2	
11	Stator coil assembly lead holder	1	
12	Stator coil assembly	1	



YAMAHA MOTOR CO., LTD.
2500 SHINGAI IWATA SHIZUOKA JAPAN

PRINTED IN U.S.A.